

## Atmel ATmega 328 PDIP

Arduino function	Pin	Atmel Pin	Atmel Function	Arduino function
reset	(PCINT14/RESET) PC6	1	28	PC5 (ADC5/SCL/PCINT13) A5
dp0 (RX)	(PCINT16/RXD) PD0	2	27	PC4 (ADC4/SDA/PCINT12) A4
dp1 (TX)	(PCINT17/TXD) PD1	3	26	PC3 (ADC3/PCINT11) A3
dp2	(PCINT18/INT0) PD2	4	25	PC2 (ADC2/PCINT10) A2
dp3 (PWM)	(PCINT19/OC2B/INT1) PD3	5	24	PC1 (ADC1/PCINT9) A1
dp4	(PCINT20/XCK/T0) PD4	6	23	PC0 (ADC0/PCINT8) A0
VCC	VCC	7	22	GND
GND	GND	8	21	AREF
crystal	(PCINT6/XTAL1/TOSC1) PB6	9	20	AVCC
crystal	(PCINT7/XTAL2/TOSC2) PB7	10	19	PB5 (SCK/PCINT5) dp13
dp5 (PWM)	(PCINT21/OC0B/T1) PD5	11	18	PB4 (MISO/PCINT4) dp12
dp6 (PWM)	(PCINT22/OC0A/AIN0) PD6	12	17	PB3 (MOSI/OC2A/PCINT3) dp11 (PWM)
dp7	(PCINT23/AIN1) PD7	13	16	PB2 (SS/OC1B/PCINT2) dp10 (PWM)
dp8	(PCINT0/CLKO/ICP1) PB0	14	15	PB1 (OC1A/PCINT1) dp9 (PWM)

## Connect these pins

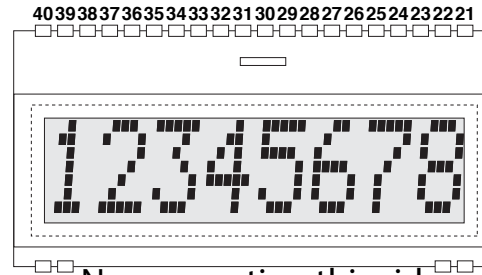

No connection this side

OK to put these pins in breadboard

## Connection for 5V only

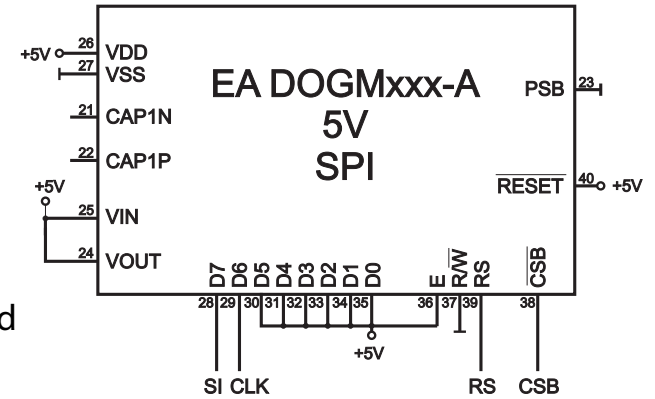

## Honeywell SS451A Hall effect switch

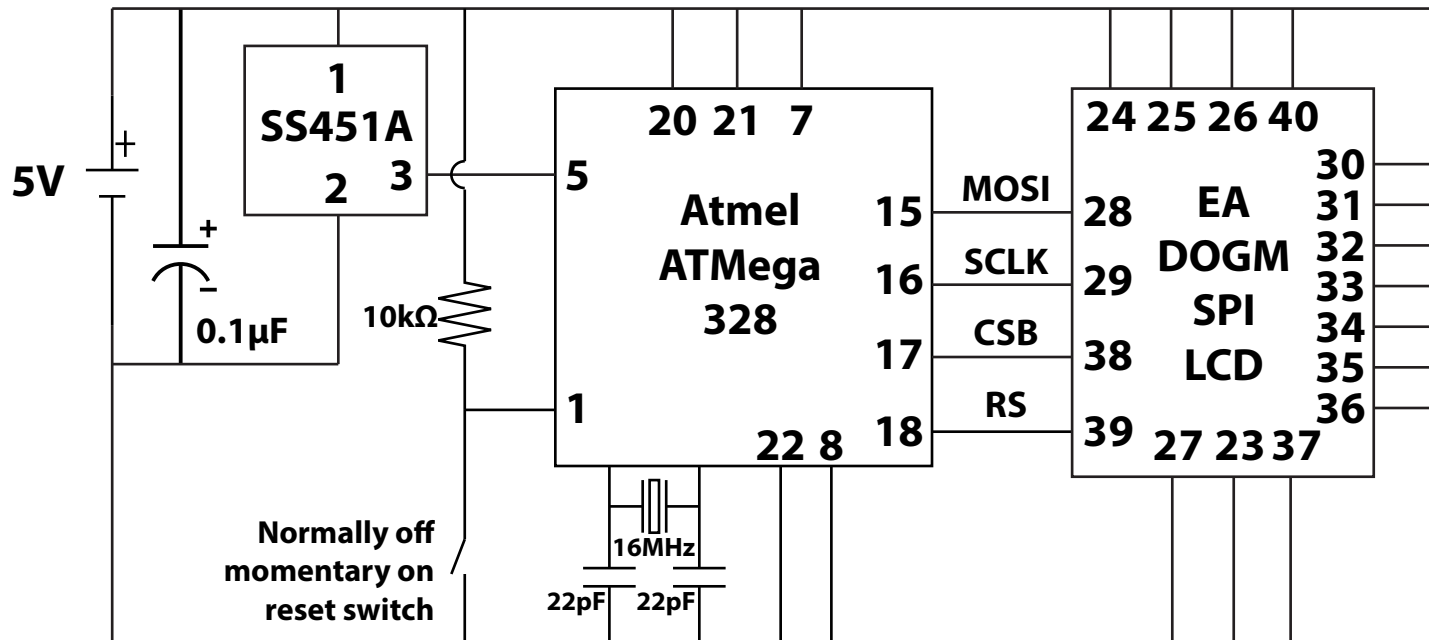
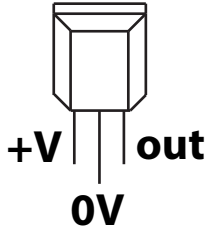

## Frequency meter

by Shawn Reeves, 2014

Note power supply voltage will affect contrast of LCD.